



# Coffee lovers' award-winning coffee maker



REMOVABLE CERAMIC LID and CERAMIC FUNNEL designed for optimal airflow and flavor extraction

STAINLESS STEEL VALVE to perfectly control the coffee drop speed and achieve the perfect taste

STAINLESS STEEL FRAME lets Gina stand firm on any flat surface

HEAT RESISTANT SILICON PAD



**GLASS PITCHER**  
made of resistant borosilicate glass  
ideal to serve your coffee or tea

**COLD DRIP MODULE**  
designed for cold drip brewing

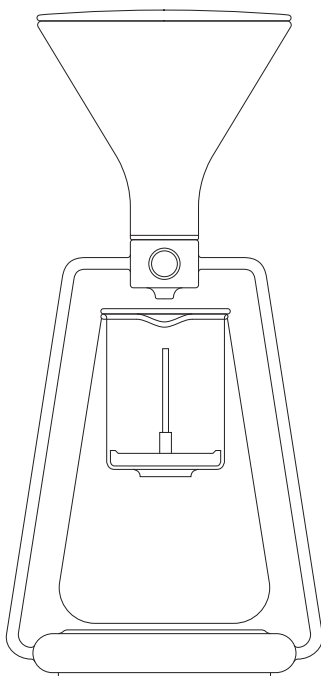

**HEIGHT**  
345 mm / 13,6"

**WIDTH**  
163 mm / 6,4"

**DEPTH**  
135 mm / 5,3"

**WEIGHT**  
1,4 kg / 3,08 lbs