

FLOJET

a xylem brand

BW5000 Series

BOTTLED WATER BOOSTER SYSTEM

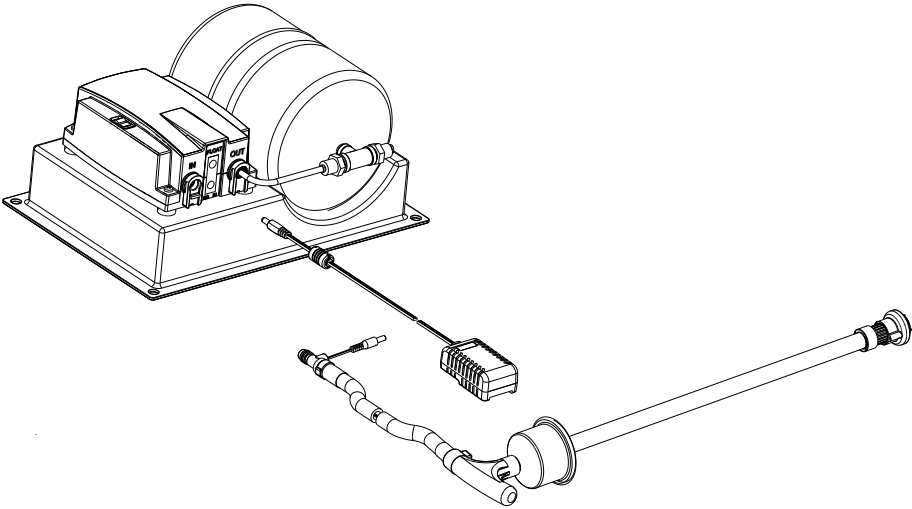
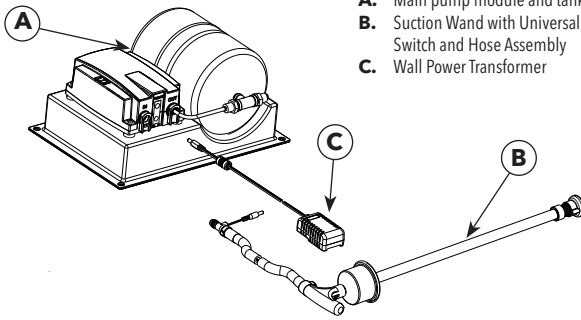
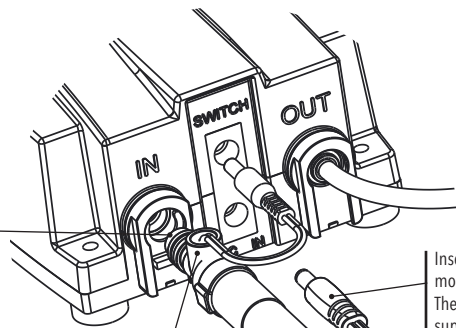
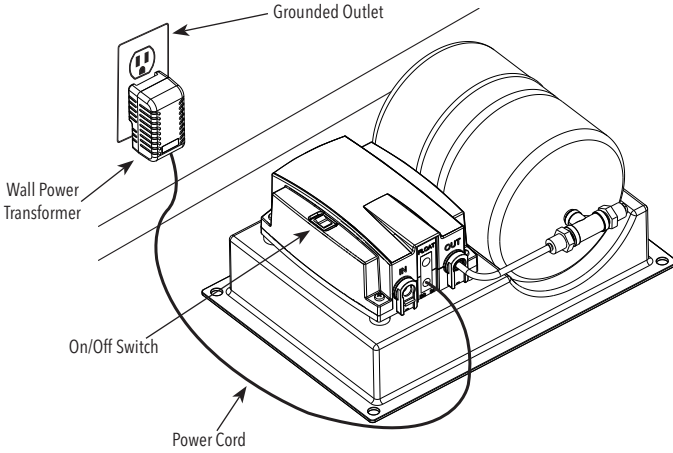

Figure 1



- A. Main pump module and tank assembly
- B. Suction Wand with Universal Cap Seal, Float Switch and Hose Assembly
- C. Wall Power Transformer



Insert float sensor switch plug/connector into pump module "SWITCH" port. The connections for the float and power supply will require moderate force to insert fully. This is a design feature that assures the connections are held securely after initial installation. **MAKE SURE PLUG / CONNECTOR IS INSERTED ALL THE WAY INTO THE CONNECTIONS. FAILURE TO INSERT FULLY WILL LEAD TO POOR OPERATION OR NO OPERATION.**

Insert DC plug/connector into pump module "DC IN" port. The connections for the float and power supply will require moderate force to insert fully. This is a design feature that assures the connections are held securely after initial installation. **MAKE SURE PLUG / CONNECTOR IS INSERTED ALL THE WAY INTO THE CONNECTIONS. FAILURE TO INSERT FULLY WILL LEAD TO POOR OPERATION OR NO OPERATION.**

Insert suction hose port fitting into pump module "IN" port and slide locking port clip in place.

Typical Beverage Installations

Coffee Cart/Kiosk

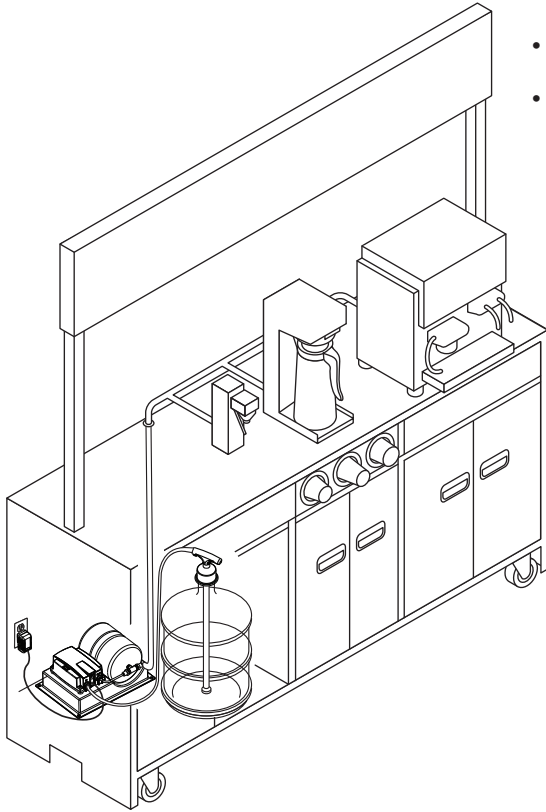

Application

- Designed for dispensing Bottled Water to coffee machines, beverage dispensers, vending machines and carts. See diagrams
- For remote locations where mains water supply is not accessible
- Ideal for under counter installation

The **Bottled Water Booster System** may also be placed in a pantry, closet, cellar or other location where a **grounded electrical outlet** is available.

Installation and Operation

Installation procedure: See Figure 1

1. Securely mount in a suitable position. If mounting vertically to a wall, ensure that the mounting fixings are suitable for the product's wet weight. Ensure that the on / off switch is accessible and that there is sufficient space above the accumulator tank to access the air valve
2. Pre-charge accumulator tank to 18 PSI (1.2 Bar) per the troubleshooting section
3. Install appropriate adapter onto the universal wall power transformer, plug into grounded electrical outlet and into the pump module
4. Fill water tank
5. Install suction wand with universal cap seal, float switch and hose assembly
6. Open all faucets and switch appliance(s) on to fill if necessary
7. Turn the ON/OFF switch located on the pump module to the "ON" position to prime pump
8. When water is free of air, turn all faucets off beginning with the faucet closest to the pump

Regular cleaning and sanitizing of the Flojet Bottle Water Booster System is required.

The BW Booster System is only to be used with the power supply provided.

Check accumulator tank pressure every 6 months and adjust as necessary.

Important: Do not operate the pump more than 20 minutes continuously.



CAUTION: This appliance can be used by children aged from 8 years and above and persons with reduced physical, sensory or mental capabilities, or lack of experience and knowledge, if they have been given supervision or instruction concerning use of the appliance in a safe way and understand the hazards involved. Children shall not play with the appliance. Cleaning and user maintenance shall not be made by children without supervision.

Specifications

Voltage	Input 100-240 VAC
Cycles	50/60 Hz
Current	1.2 Amps Max.
Maximum Pressure	40 PSI (2.8 Bar) Max.
Accumulator Air Tank Pressure	18 PSI (1.2 Bar)
Housing Material	ABS
Shipping Weight	4.6 lb. (2.1 kg)
Wet Weight	7.5 lb (3.4 kg)
Overall Dimensions	11.5 in L x 10.5 in W x 7.1 in H 292 mm x 267 mm x 181 mm
Fluid Outlet	3/8" (9.5mm) OD Push-in Tube

Application Notes & Troubleshooting

System will not dispense fluid

- Check ON/OFF switch position
- Check power to dispensing system
- Check tubing and fluid connections
- Check for empty fluid container
- Check power cable is fully inserted and switched on at the mains

System will not shut-off

- Check for leaks in tubing system
- Check for air in system, purge air

Low flow or system continually turns on and off

- Check accumulator air pressure
 1. Wear appropriate safety gear
 2. Turn off power and relieve water pressure
 3. Unscrew valve cap and adjust air pressure to 18 PSI (1.2 Bar)

MAINTENANCE AND SANITATION

Equipment Required

- 2.5 gal (9.6 L) Household Pails
- One (1) Roll of Paper Towels
- One (1) Small Container of Household Bleach

Clean In-Place Procedure

1. Using the on/off switch on the front of the enclosure, turn BW Booster Series off by putting the switch in the off position.
2. Fill a clean pail (A) with two (2) gal (7.57 L) of hot tap water (135°F / 57.2°C), adding one (1) oz (29.57 ml) of household bleach.
3. Remove the suction wand from the pure water bottle and submerge the bottle cap end into pail (A), taking care to ensure that the metal hose clamp connecting the hose to the suction wand(s) is/are totally immersed in the water/bleach solution, for ten minutes and then wash underside of cap and suction tube exterior with a clean paper towel. If using the optional Flojet faucet, disconnect the tubing. Remove the faucet, immersing it in the water/bleach solution for ten minutes. Wash the faucet exterior with clean paper towel; install the faucet and reconnect the tubing. Place suction wand into clean empty pail (B) and dispose of solution in pail (A).
4. Refill the cleaned pail (A) with two (2) gal (7.57 L) of hot tap water (135°F / 57.2°C) adding one (1) oz (29.57 ml) of household bleach and place suction wand(s) into pail with bottle cap up.
5. Disconnect the discharge tube from the faucet and place into the empty second pail (B). (Do not use pail with clean water and chlorine solution).
6. Turn dispensing system on, by placing on/off switch in the on position and dispense all of the chlorine solution into pail (B). Place discharge tube into pail (A) and dispose of bleach, and rinse pail (B). Replace tube into pail (B).
7. Refill pail (A) with two (2) gal (7.57 L) of hot tap water (135°F / 57.2°C), adding one (1) oz (29.57 ml) of household bleach. Dispense bleach as in step #6.
8. Reinstall suction wand(s) into new bottle(s) of pure water and reconnect discharge tube into refrigerator or faucet and dispense 12 to 18 oz (355 to 532 ml) of water, or until bleach taste is removed.
9. Cleaning should be performed at least six (6) times per year. System should be cleaned and flushed with fresh water if stagnant for more than 48 hours.

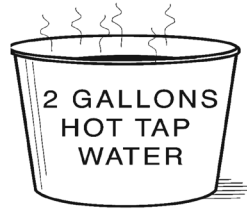

CAUTION!
135°F (57.2°C)
Maximum Water
Temperature

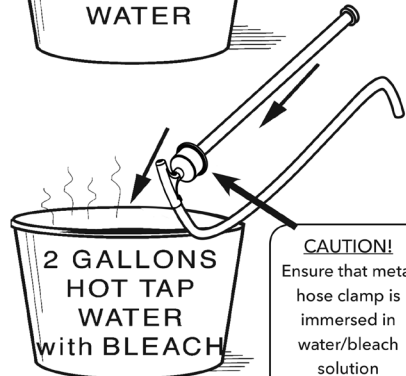
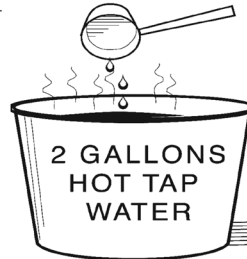

CAUTION!
Ensure that metal
hose clamp is
immersed in
water/bleach
solution



CAUTION

Do not place BW Booster Series into a dishwasher as it will cause electrical failure of pump and controls.



CAUTION: Do not place BW Booster System into a dishwasher as it will cause electrical failure of pump and controls.



CAUTION: Not intended for outdoor use.



CAUTION: The BW Booster System must be installed in an enclosure and/or protected from any splash or spillage.



CAUTION: To avoid exposure to freezing conditions, prior to storing, cleaning and servicing of pumps, purge all liquid from the pump. Allowing water to freeze in the system may result in damage to the pump and plumbing system.



Only used with specified products. DO NOT PUMP LIQUIDS WITH A FLASH POINT BELOW 100°F (37.8°C) OR USE WHERE FLAMMABLE VAPORS ARE PRESENT. Doing so may result in explosion which could cause personal injury, death or property damage.

WARRANTY

XYLEM LIMITED WARRANTY WARRANTS THIS PRODUCT TO BE FREE OF DEFECTS AND WORKMANSHIP FOR A PERIOD OF 4 YEARS FROM DATE OF MANUFACTURE ON THE BOTTLE WATER PUMP AND WAND, 1 YEAR FROM DATE OF MANUFACTURE ON TO THE ACCUMULATOR TANK ASSEMBLY. THE WARRANTY IS EXCLUSIVE AND IN LIEU OF ANY AND ALL OTHER EXPRESS OR IMPLIED WARRANTIES, GUARANTEES, CONDITIONS OR TERMS OF WHATEVER NATURE RELATING TO THE GOODS PROVIDED HEREUNDER, INCLUDING WITHOUT LIMITATION ANY IMPLIED WARRANTIES OF MERCHANTABILITY AND FITNESS FOR A PARTICULAR PURPOSE, WHICH ARE HEREBY EXPRESSLY DISCLAIMED AND EXCLUDED. EXCEPT AS OTHERWISE PROVIDED BY LAW, BUYER'S EXCLUSIVE REMEDY AND SELLER'S AGGREGATE LIABILITY FOR BREACH OF ANY OF THE FOREGOING WARRANTIES ARE LIMITED TO REPAIRING OR REPLACING THE PRODUCT AND SHALL IN ALL CASES BE LIMITED TO THE AMOUNT PAID BY THE BUYER HEREUNDER. IN NO EVENT IS SELLER LIABLE FOR ANY OTHER FORM OF DAMAGES, WHETHER DIRECT, INDIRECT, LIQUIDATED, INCIDENTAL, CONSEQUENTIAL, PUNITIVE, EXEMPLARY OR SPECIAL DAMAGES, INCLUDING BUT NOT LIMITED TO LOSS OF PROFIT, LOSS OF ANTICIPATED SAVINGS OR REVENUE, LOSS OF INCOME, LOSS OF BUSINESS, LOSS OF PRODUCTION, LOSS OF OPPORTUNITY OR LOSS OF REPUTATION. THIS WARRANTY IS ONLY A REPRESENTATION OF THE COMPLETE LIMITED WARRANTY. FOR A DETAILED EXPLANATION, PLEASE VISIT US AT www.xylem.com/en-us/support/, CALL OUR OFFICE NUMBER LISTED, OR WRITE A LETTER TO YOUR REGIONAL OFFICE.

RETURN PROCEDURE

Warranty returns are conducted through the place of purchase. Please contact the appropriate entity with a receipt of purchase to verify date.

FLOJET

a **xylem** brand

Xylem Inc. – USA

17942 Cowan
Irvine, CA 92614

Xylem Inc. – UK

Harlow Innovation Park,
London Road, Harlow, Essex, CM17 9LX

Xylem Inc. – CHINA

30/F Tower A, 100 Zunyi Road, Shanghai
200051

Xylem Inc. – HUNGARY KFT

2700 Cegléd
Külso-Kátai út 41

Xylem Inc. – AUSTRALIA

2/2 Capicure Drive
Eastern Creek, NSW 2766

www.xylem.com/flojet

© 2022 Xylem Inc. All rights reserved

Flojet is a trademark of Xylem Inc. or one of its subsidiaries

81000918 Rev. A 06/2022